

pre@flow[®] Dosing system

by ViscoTec

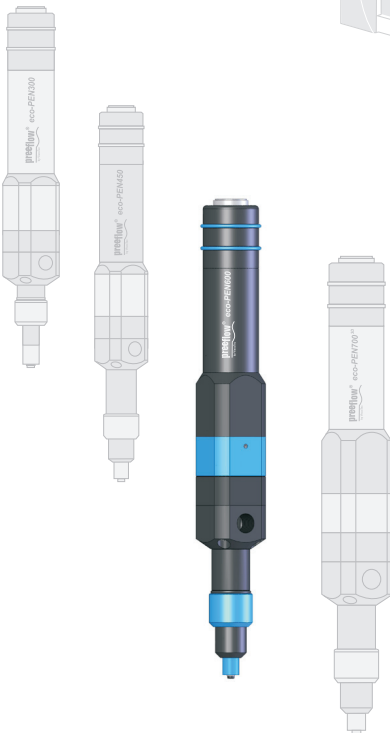
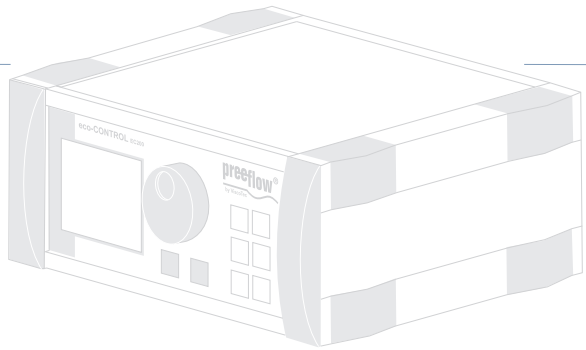

Commissioning and maintenance manual

eco-PEN600

Contents

1	This manual	5
2	The dispenser	5
3	Safety	5
4	Starting up for the first time	6
	4.1 Inserting the stator	6
	4.2 Connecting the dosing unit to the drive unit	7
	4.3 Supply and bleed the medium.	7
5	Connection options	9
6	Cleaning	10
7	Spare parts	11
8	Maintenance	12
	8.1 Changing the stator	12
	8.2 Troubleshooting	12
9	Disposal	12
10	Technical specifications	13

1 This manual

Dear customer,

This manual forms part of the operating and maintenance manual for the dosing system eco-CONTROL EC200. The operating and maintenance manual must have been read and understood in full before commissioning or carrying out maintenance work on the eco-PEN600.

2 The dispenser

The dispenser is supplied with these components and accessories:

- A Dosing unit
- B Stator
- C Drive unit
- D Assembly aid
- E Installation tool
(2 Allen wrenches)

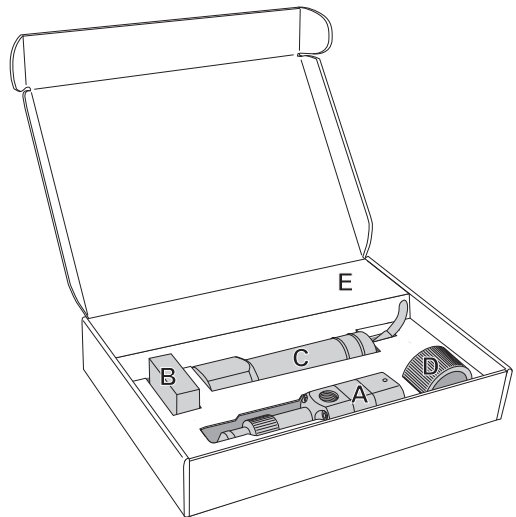

Fig. 1

3 Safety

All instructions in the Safety section of the maintenance and operating manual for the dosing system must be complied with and implemented.

4 Starting up for the first time



Dispenser **Do not switch on** until medium has been delivered to it. Otherwise there is a risk of **damage to the equipment. Even a brief period of dry running can lead to the stator being destroyed.**

4.1 Inserting the stator

Preparation: Unplug the power supply to the drive unit.

1. Undo the union ring (2).
2. Pull off the end piece (3).
3. Couple the assembly aid (6) to the dispenser housing (10) (the star-shaped coupling (5) must be attached to the dispenser housing).
4. Wet the rotor (4) with the medium or a suitable lubricant.
5. Turn the stator (7) (on the bearing side, see Fig. A) on the rotor (4) until the dowel pin begins to dip into the keyway (9).
6. Lightly press the stator in the direction of the dispenser housing (10) and turn the assembly aid in the direction of the arrow until the stator has been guided into the dispenser housing.
7. Uncouple the assembly aid, install the end piece and the union ring, and put in place the required Luer-Lock needle.

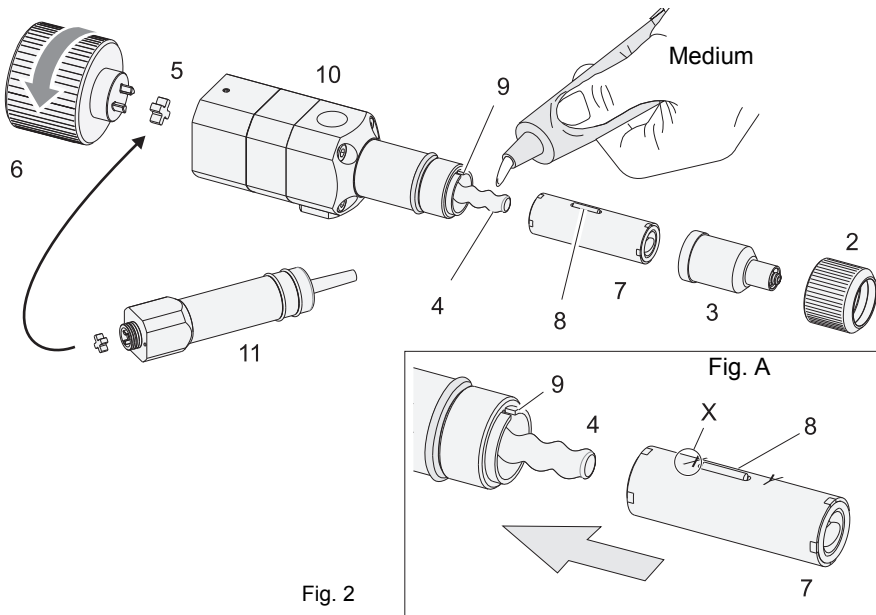

4.2 Connecting the dosing unit to the drive unit

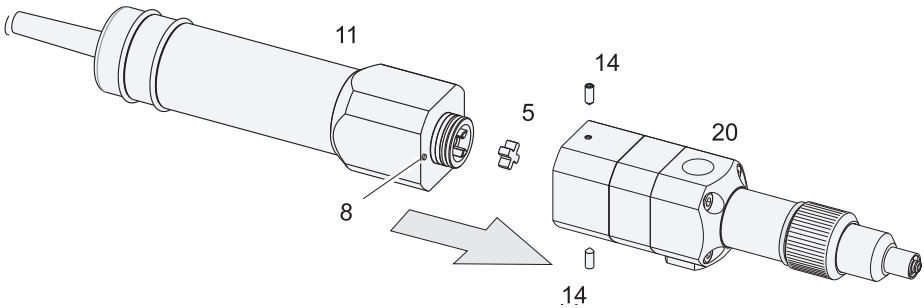

Fig. 3

1. Turn the set screws (14) in the thread such that they do not protrude into the coupling area. **Danger of damage to the fit.**
2. Attach the star-shaped coupling (5) onto the coupling of the drive unit (11).
3. Couple the drive unit (11) to the dosing unit (20) until there is a gap <1 mm between the anti-rotation lock (8) and the dosing unit (20).
4. Set the anti-rotation lock (8) correctly in place by rotating the dosing unit (20).
5. Bring the drive unit (11) and the dosing unit (20) together completely.
6. Lightly turn the set screws (14), the drive unit (11) has now been centred properly.

4.3 Supply and bleed the medium.



Follow the safety stipulations and instructions of the manufacturer of the medium to be used to fill the unit. If applicable, use the required protective equipment. If the medium is being conveyed for the first time, there is a **danger from medium spurting out**. Air bubbles can cause uncontrollable spurting out. Ensure that you stand back a safe distance.

- Connect the tank (supply line, cartridge) of the medium to the dispenser medium input (12). (See section 10, *Technical specifications*, page 13 for details of the thread)

The Dispenser can be bled in one of two ways after the medium has been supplied.

Version A

(e.g. supply via a hose, closed cartridge)

- Dispenser bring it into a position in which the end piece (3) points upwards.
- Dispenser connect the unit to the power supply and convey the medium until there are no more air bubbles in it and the outlet nozzle (with the Luer-Lock needle) comes out.

Tip: Connecting a hose can protect the Dispenser from being wetted with the medium.

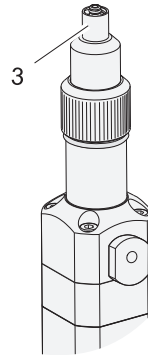

Fig. 4

Version B

(e.g. open cartridge, Dispenser fixed in place and supply of the medium under pressure)

- Turn the bleed screw (23) 180 degrees so that the bleed hole is in the position shown (direction of the drive unit).
- wait until the medium emerges from the bleed hole free from air bubbles.
- Release (remove) the primary pressure on the medium and wait until no more medium comes out of the bleed opening.
- Remove the ejected medium and close the bleed screw (23) again.

Connect the Dispenser to the power supply and convey the medium until there are no more air bubbles in it and the outlet nozzle (with the Luer-Lock needle) comes out.

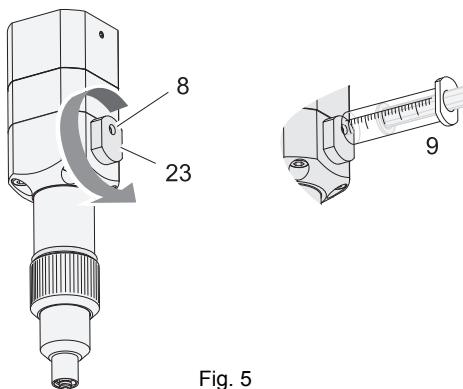

Fig. 5

Alternatively, the air can also be extracted from the pump area with the syringe (9) included in the scope of supply.

5 Connection options

Self-levelling liquid, low viscosity medium

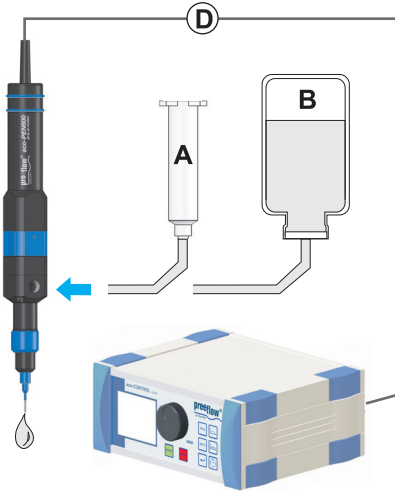

Fig. 6

Supply of the medium from a cartridge (A) or a bottle (B).

D Power supply drive unit

Note: Select the size of the hose to be such that the liquid comes out by gravity and without any air bubbles at the Dispenser. Self-suction is possible.

Not a self-levelling liquid, medium/high viscosity medium

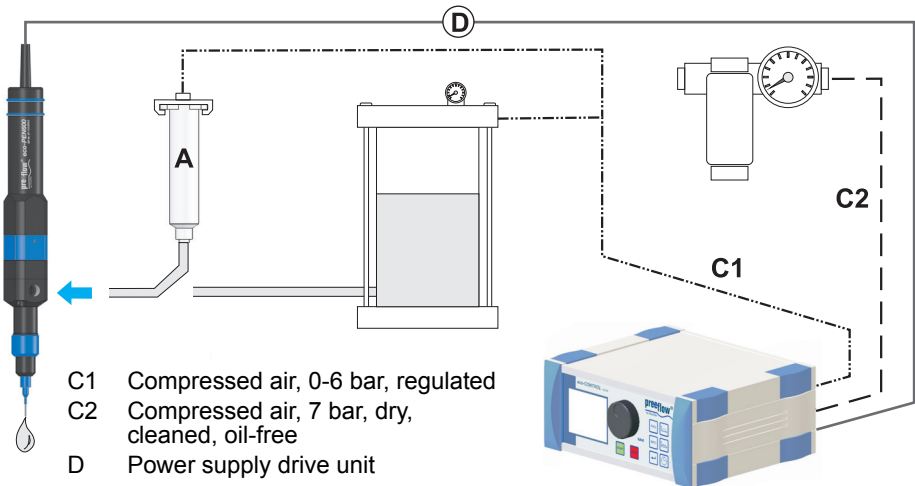

C1 Compressed air, 0-6 bar, regulated

C2 Compressed air, 7 bar, dry, cleaned, oil-free

D Power supply drive unit

Fig. 7

1. Cartridge (A) supplied with compressed air (C1), connected to the Dispenser.
2. Medium supply from the pressure tank (C).

6 Cleaning



Preparation:
Remove the dosing needle, **danger of injury!**

Disconnect the power supply of the drive unit and uncouple it from the dosing unit (in the reverse order to that described in 4.2, *Connecting the dosing unit to the drive unit*, page 7).

1. Undo the screws (18) and pull out the front dispenser housing (19) with the O-ring (22) from the module (15) while turning it slightly.

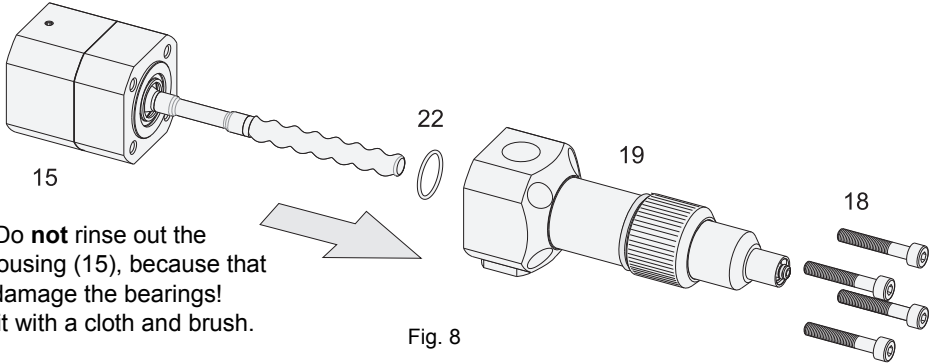

Note: Do **not** rinse out the rotor housing (15), because that could damage the bearings!
Clean it with a cloth and brush.

2. Undo the union ring (2).
3. Pull off the end piece (3).
4. Pull the stator (7) out of the front dispenser housing (19).
5. Undo the bleed screw (23) and the washer (24).
6. Clean all the parts.

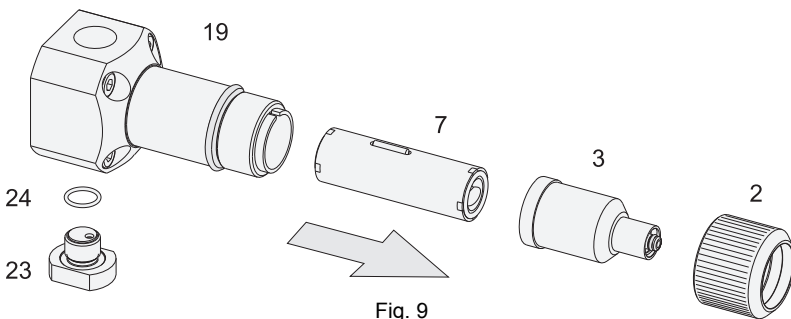

Assembly:

1. Attach the dispenser housing (19) with the O-ring (22) to the module (15) with the screws (18) (do not exceed a tightening torque of 0.5 Nm).
2. Install the stator in accordance with work steps 3. to 7. described in section 4.1, *Inserting the stator*, page 6.
3. Connect the dosing unit to the drive unit (see 4.2, page 7).

7 Spare parts

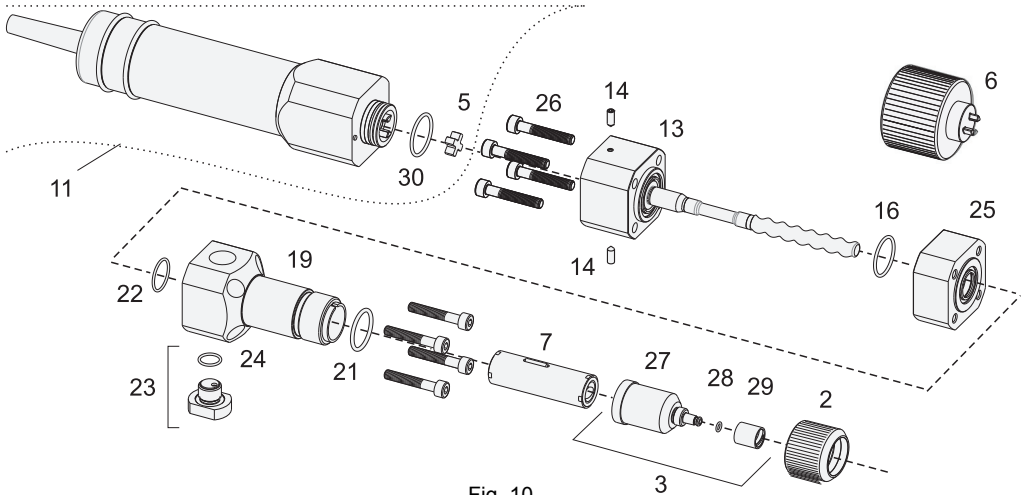

Fig. 10

Item	Part No.	x	Item name	Material
	20046		Dosing unit eco-PEN600 cpl. (without 11)	
2	20016		Union ring eco-PEN600	Aluminium
3	20023		End piece eco-PEN600 with Luer-Lock cpl.	POM
5	20050	x	Star-shaped coupling	Elastomer
6	20108		Assembly aid	Aluminium
7	20002	x	Stator cpl. eco-PEN600	VisChem
11	20047	x	Drive unit eco-PEN600 cpl.	
13	20152		Bearing housing with rotor set cpl.	
14	20029		Set screw	A2
16	20007	x	O-ring Ø 16 x 1.25	FKM
18	20031		Allen screw	A2
19	20012		Dispenser housing eco-PEN600	POM
21	20017	x	O-ring Ø 16 x 2	NBR
22	20011	x	O-ring Ø 13	FKM
23	20510		Bleed screw cpl.	POM
24	20513	x	O-ring Ø 8	FKM
25	20151		Seal set with housing	
26	20031		Allen screw	A2
27	20020		End piece eco-PEN600 with Luer-Lock	POM
28	20035	x	O-ring	FKM
29	20021		Threaded sleeve Luer-Lock	Aluminium
30	20041	x	O-ring Ø 17	NBR

x = recommended spare parts ad wearing parts

8 Maintenance

8.1 Changing the stator

- Remove the defective stator (see section 6, *Cleaning*, page 10)
- Install the new stator (see "Assembly" in section 6, *Cleaning*, page 10)

8.2 Troubleshooting

Error	Possible cause	Correction
No or too little medium conveyed	Needle blocked	Clean / replace the needle
	Medium hardened	Dispenser clean
	Needle too small or too long	Use a different needle cross-section. Reduce the speed / flow rate.
	Stator swollen	Replace the stator
	Inadequate supply of medium	Supply the medium, check the hose, check the primary pressure and increase it if necessary.
Dripping / running on of the medium	Motor not connected	Connect the motor
	Sucking back not set correctly	Set the sucking back
	Air bubbles in the medium	Bleed the medium
	Medium compressible	Degas the medium

9 Disposal



The final disposal of the Dispenser is to be done in an environmentally-appropriate way. All the materials and packaging must be handled in accordance with the recycling stipulations. 1.6

Do not dispose of electrical parts in the household garbage.

They are to be taken to the appropriate collecting points.

2002/96/EU(WEEE)* EU DIRECTIVE concerning used electrical and electronic equipment

10 Technical specifications

Dimensions	Lenght, 274 mm, □ 34 x 34 mm, ø 40 mm
Weight	ca. 750 g
Material infeed	1/4" cylindrical whitworth pipe thread DIN/ISO 228
Material outfeed	Luer lock with O ring, patented
Min. operating pressure	0 bar, self-levelling-fluid
Max. operating pressure	0 to 6 bar input pressure, non-self-levelling-fluid
Max. dosing pressure	16 to 20 bar
Intrinsic tightness *	approx. 2 bar (reference medium approx. 10mPas at 20°C)
Parts in contact with the media	HD-POM / stainless steel
Seals	High-molecular PE, VisChem
Static seals	Viton O ring (medium) NBR (dust)
Motor	18 - 24 V DC, incremental encoder, planetary gears
Operating conditions	+10°C to +40°C, air pressure 1 bar
Medium temperature	+10°C to +40°C
Storage environment	dry & dust-free, -10°C - +40°C
Approx. dosing volume per revolution	0.14 millilitres per revolution
Accuracy of dosing **	± 1%
Repeat accuracy	> 99%
Min. dosing quantity	0.004 millilitres
Volume flow ***	1.4 to 16.0 millilitres per minute

* Max. dosing pressure and intrinsic tightness will decrease in direct proportion to a decrease in viscosity and increase in direct proportion to an increase in viscosity. Consultation with the manufacturer recommended.

** Volumetric dosing as absolute deviation in relation to one dispenser revolution. Depends on the viscosity of the dosing medium.

*** Volume flow depends on viscosity and primary pressure.

Threads used

Medium input	1/4" cylindrical Whitworth pipe thread DIN / ISO 228
Bleed hole	Luer DIN EN 20594-1
Nozzle connection	LUER-LOCK DIN EN 1707 with O-ring, patented

Materials used

Dispenserhousing, end nozzles	HD-POM
Dispenserparts, motor housing	Anodized aluminium
Screws, washers, etc.	Stainless steel A2
Stator elastomer, flexible shaft covering	VisChem

Shaft sealing rings	Z80
O-rings	FKM
Drive shaft, rotor	Stainless steel A4

--	--	--	--



info@preeflow.com
www.preeflow.com